

Dispermill M-series

The Dispermill M-series upscales your laboratory projects to production scale. This universally applicable machine is suitable for batches from 75 to 1000 liters and comes with high-end technology to increase the ease of use.

DESIGNED FOR YOU

The Dispermill M-series has been developed according to the latest technical requirements. This dissolver has a hydraulic cylinder for easy up and down movement of the entire mixing unit. The stainless steel mixing shaft is equipped with double bearings. The ergonomically designed control panel gives you control over the machine and has a display where you can easily read the speed. The powerful drive in combination with the ABB microprocessor-controlled motor ensures highly reliable functionality. In addition, this machine has a very compact design, making it easy to fit into your factory.

PRODUCT APPLICATIONS

Paints, floor coatings, ceramics, colourants, automotive coatings, inks, sealants, PVC liquids, aerospace coatings, industrial coatings, resin, putties, decorative coatings, textile, additives, wood coatings, plasters, stucco/wall and adhesives.

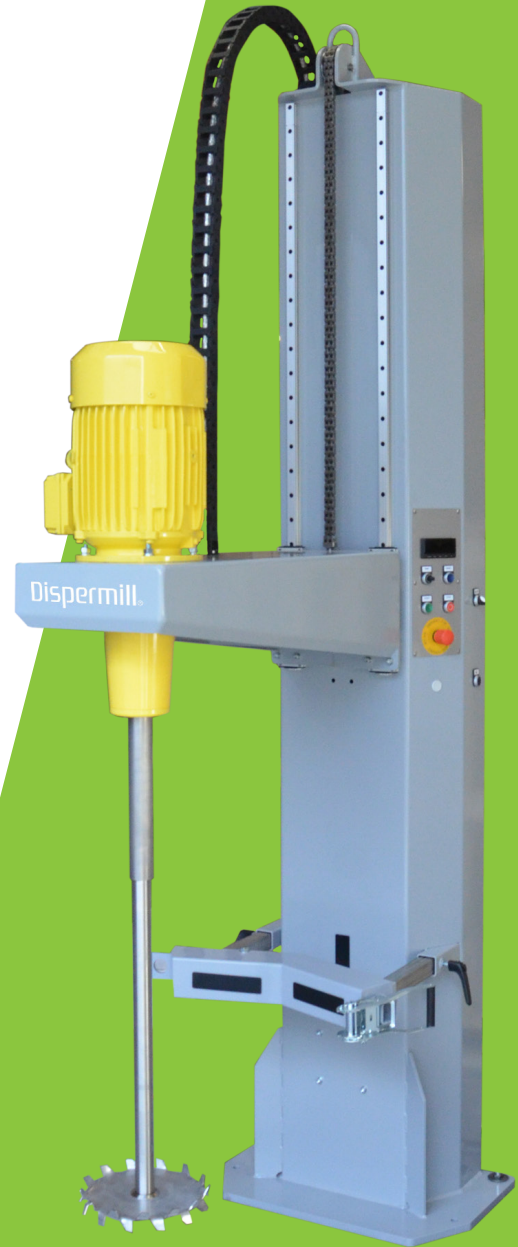

FEATURES

- ✓ Hydraulic lifting system
- ✓ Clear digital speed readout
- ✓ Space-saving design
- ✓ Wide variation in power and speed frequency
- ✓ Clamping system by ratchet belt
- ✓ Available in ATEX version
- ✓ Direct drive system

Dispermill M-series	Order code*
M400 , 4,0 kW, 200 - 1800 RPM	10-1032
M550 , 5,5 kW, 200 - 1800 RPM	10-1042
M750 , 7,5 kW, 200 - 1800 RPM	10-1083
M1100 , 11,0 kW, 200 - 1800 RPM	10-1026
M1500 , 15,0 kW, 200 - 1800 RPM	10-1124

Dispermill MX-series (ATEX)	Order code*
MX400 , 4,0 kW, 200 - 1800 RPM	10-1031
MX550 , 5,5 kW, 200 - 1800 RPM	10-1012
MX750 , 7,5 kW, 200 - 1800 RPM	10-1062



*Note: customized machines get new codes depending on configuration.

ENHANCED EASE OF USE

OPERATIONAL

The Dispermill M-series is suitable for:

- Mixing and homogenizing of color pigments
- Direct mixing in IBC container
- Pre-dispersing before the milling process
- Mixing of the end product
- Dispersing solids into liquids
- Mixing of liquids into liquids



Option: direct mixing in IBC container

INSTALLATION

The machine is pre-wired, so it just needs to be anchored to the floor and the electrical cabinet to be mounted on the wall. For ATEX version the electrical cabinet needs to be installed outside the ATEX zone.



USER INTERFACE

The user interface provides optimal control and includes:

- Start / Stop buttons
- Turning knob for speed setting
- Digital speed readout
- Emergency button

OPTIONS

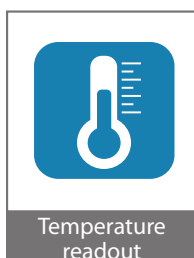
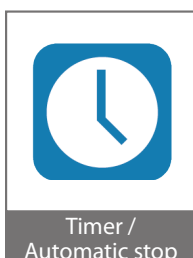

Option: integrated lid to cover the vessel

CUSTOMIZED

We can process any configuration that suits your requirement. Is your option not listed in this brochure? Please contact our sales department through phone or e-mail.

+41 (0)61 816 80 80
 info@ingtec-technik.ch

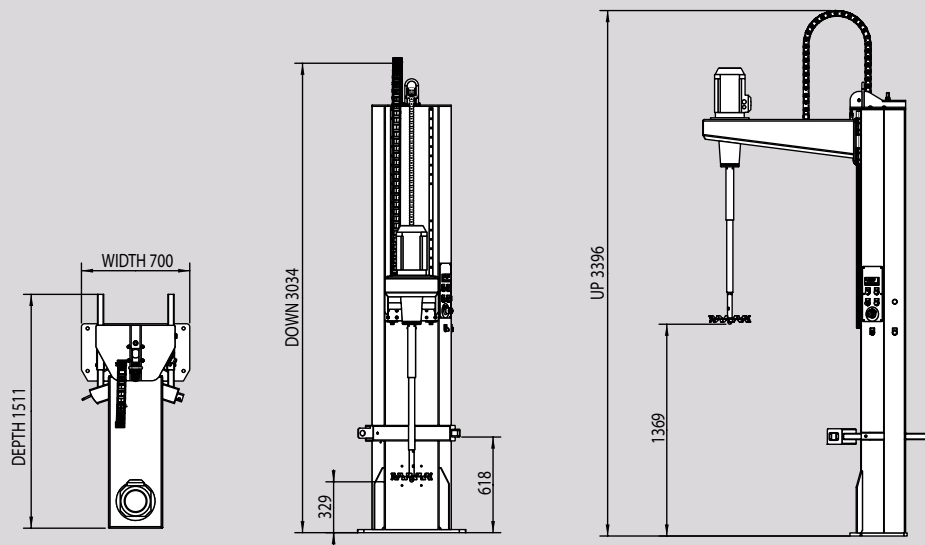

TECHNICAL SPECIFICATIONS

	Power	Torque	Dispersing disc incl.	ATEX	Order code
M400	4.0 kW / 5.5 HP	25 Nm	200		10-1032
M550	5.5 kW / 7.5 HP	35 Nm	225		10-1042
M750	7.5 kW / 10 HP	48 Nm	250		10-1083
M1100	11,0 kW / 15 HP	70 Nm	275		10-1026
M1500	15,0 kW / 20 HP	95 Nm	325		10-1124
MX400	4.0 kW / 5.5 HP	25 Nm	200	Ex	10-1031
MX550	5.5 kW / 7.5 HP	35 Nm	225	Ex	10-1012
MX750	7.5 kW / 10 HP	48 Nm	250	Ex	10-1062

The specifications below apply to all models.

Speed	200 - 1800 RPM
Supply	400 V +/- 10% 50/60 Hz
Thermal protection	PTC Temperature sensors
Electrical connection	5m cable with separate electric cabinet
Volume range vessel	75 - 1000 L
Height vessel	1270 mm max.
Dimensions (in mm)	700 x 1511 x 3034/3396 (W x D x H)
Safety CE	Conformity Directive 2006/42/EC

OPTIONS

	Order code
IBC Version	+020
IBC detection clamp	+032
Oscillation (Up and down movement)	+025
Timer with Automatic stop	+011
Temperature probe and readout	+014
Temperature probe and readout (ATEX)	+014
Power readout in kW	+015
Power readout in kW (ATEX)	+015
Lid to cover the vessel	+050